

# USER MANUAL

## 2.0 - DESCRIPTION OF ALARM SYSTEM CONTROL DEVICES

The alarm system can be operated by:

- **Remote control with two push-buttons:** which activates all the alarm functions.
- **Electronic key:** which activates only some functions of the alarm system and is used for emergency disarming.
- **PIN-CODE:** for emergency disarming.

### 2.1 - REMOTE CONTROL (all alarm systems)

The remote control is the most frequently used "interface" used by the user.

We recommend you familiarize thoroughly with the remote control.

To recognize the buttons more easily they each have a different texture.

The arming/disarming button is rough while the one used for operating the siren is smooth.

To prevent problems with the remote control, it has been provided with a device that will signal the charge condition of the batteries inside.

During normal use of the remote control, when you press a command button, the green LED will light up with a steady light.

If the battery charge drops below the level needed to assure correct operation of the remote control, when you press a command button, the green LED will blink, advising you that it is time to replace the batteries

#### Push-button 1 (dotted):

- Arming/disarming of alarm system.

#### Push-button 2 (smooth):

- Panic alarm activation/deactivation.
- Siren exclusion during an alarm condition ("mute" function).
- To silence the siren during an alarm condition.

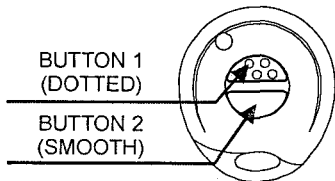

*The different tactical feel of the buttons prevents accidental activation of the panic alarm (ex. when it's dark or when operating the remote from your pocket).*

### 2.2 - ELECTRONIC KEY (602687M, 602688M and 602820M)

The electronic key can be used like a kind of "simplified remote control" or device for emergency disarming.

#### Simplified remote control:

- Insert the key in its receptacle to arm and disarm the alarm system.

#### Emergency disarming device:

- In case of need, loss of remote control, insert the key in its receptacle to disarm the alarm system.

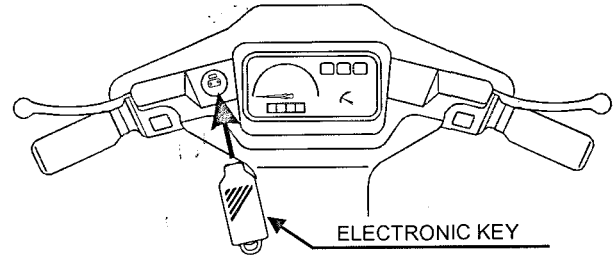

### 2.3 - PIN-CODE (all alarm systems)

The PIN-CODE allows you to disarm the alarm system in case of need, i.e. when both remote control and electronic key are lost.

Once the PIN-CODE procedure is activated, the user must enter a 4-digit numerical code by turning ignition key ON and OFF.

The LED on the vehicle will flash and the number of flashes will indicate the value of the digit entered.



## **3.0 - SYSTEM OPERATING IN BASIC CONFIGURATION**

This chapter describes the system working in "basic" configuration. The user can customize the configuration following instructions in "PROGRAMMING OF THE SYSTEM" chapter (8.0).

### **3.1 - ARMING**

Pressing the button N.1 (dotted) on the remote control (all models) or inserting the electronic key into the receptacle (only for models 602687M, 602688M and 602820M), the alarm system will be armed.

This action is indicated by one flashing of the turn signals, one acoustic signal with high pitch (BEEP) and the LED installed on the vehicle will turn on steady.

### **3.2 - SIREN EXCLUSION ("mute" function)**

Once the arming signals are over, the siren can be excluded ("mute function") during an alarm condition.

To silence the siren, press the button n. 2 (smooth) on the remote after having activated the alarm system.

Siren exclusion will be signalled by a short flashing of the turn signals and is bound to each arming cycle.

### **3.3 - ARMING NEUTRAL TIME**

Once the arming signals are over, the system will automatically be in stand-by (neutral time) and the LED on the vehicle will turn on steady.

While in this condition, the alarm system does not detect theft attempts on the vehicle but the immobilizer is active (only for models 602688M and 602689M).

Neutral time lasts about 20 seconds.

### **3.4 - ALERT MODE**

At the end of the neutral time, the alarm system goes in the armed condition and signals this with a blinking LED.

From now on, the system is armed and ready to signal possible attempts.

### **3.5 - ALARM**

If, during the alert condition there is a theft attempt, the system will indicate this by activating the high-tone siren (if not previously excluded), lighting up the LED steady and causing the turn indicators to flash repeatedly for about 30 seconds.

During the alarm condition the siren can be temporarily silenced without disarming the system, by pressing the button n. 2 (smooth) on the remote.

The alarm may be activated by the following causes:

- Shock detection (if sensor is enabled).
- Ignition detection. Only mod. 602820M: this alarm is triggered after a 2" delay.

- Seat or top case opening (only model 602687M).
- Power supply cables cut-off (only model 602688M).
- Panic alarm function activation (if enabled).

During this lapse of time the LED on the vehicle will stay ON steady and when the alarm signals are over, the system will return in the alert mode in about 5".

### **3.6 - LIMITATION OF AUDIO ALARM**

Alarm conditions caused by shock detection or seat/trunk opening (only for model 602687M) will be signalled by the activation of the siren for 5 consecutive times.

From the sixth alarm condition on, the siren will no longer sound for the following reasons:

- If after 5 times no one checks the vehicle, it is useless to have it sound again.
- Reduction of power consumption to extend the vehicle battery life.
- Compliance with the environmental noise regulation (acoustic emissions caused by vehicle alarm systems) and PIAGGIO is always very much involved and aware of environmental noise pollution.

### **3.7 - SYSTEM DISARMING WITHOUT ALARM MEMORY**

To disarm the system when it is activated, press button n.1 (dotted) or insert the electronic key in its receptacle (only for models 602687M, 602688M and 602820M).

Disarming will be indicated by 3 high pitched acoustic signals (BEEP), 3 flashes of the turn indicators and the LED on the vehicle will turn OFF.

### **3.8 - SYSTEM DISARMING WITH ALARM MEMORY**

If during the alert condition attempts have been made to force the vehicle, during the deactivation stage the system will signal the event with two flashes of the turn indicators and, simultaneously, with two low-tone beeps.

The last cause of alarm will be signalled by one or more flashes of the turn indicators and a corresponding number of acoustic signals, according to the type of event, as indicated hereafter.

**Shock detection alarm:** one flash of the turn indicators, one flash of the LED and an acoustic signal with high tone (BEEP).

**Ignition detection alarm:** two flashes of the turn indicators, two flashes of the LED and two acoustic signals with high tone (BEEP).

**Seat opening alarm (only for model 602687M):** three flashes of the turn indicators, three flashes of the LED and three high tone acoustic signals (BEEP).

**Power supply cut alarm (only for model 602688M):** four flashes of the turn indicators, four flashes of the LED and four high tone acoustic signals (BEEP).

#### 4.0 - REPLACEMENT OF REMOTE CONTROL BATTERIES

- Open the remote control covers being careful not to damage the internal circuit.
- Remove the discharged batteries.
- Insert the new batteries in their housing, being careful to not invert the polarity.
- Close the plastic covers of the remote.
- Verify the efficiency of the remote control.

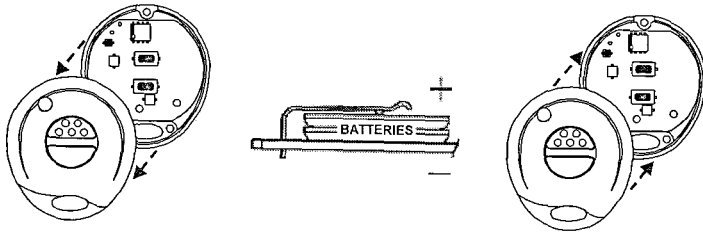

#### WARNING!

Use only batteries CR1616 type.  
Using batteries different from those advised can seriously damage the remote control unit.  
Do not discard used batteries in the environment; they should be disposed in appropriate containers.

#### 5.0 - SYSTEM MANAGEMENT IN EMERGENCY CONDITION

This chapter explains how to disarm the system in an "emergency" condition, i.e. when, for some reason, it cannot be done with the remote control and the vehicle cannot be used.

##### 5.1 - EMERGENCY DISARMING BY ELECTRONIC KEY (602687M, 602688M and 602820M)

Insert the electronic key in the receptacle; the alarm system will be immediately disarmed and the operation confirmed as indicated in paragraphs "system disarming without alarm memory" or "system disarming with alarm memory".

##### 5.2 - EMERGENCY DISARMING BY PIN-CODE (all models)

If both the remote and the electronic key are lost, the system will have to be disarmed with the PIN-CODE procedure.

Proceed as follows or go to the next chapter for an illustrated example on how to disarm by PIN-CODE:

- Cause an alarm situation; as soon as the alarm condition is over, the LED will turn on steady for about 5".
- While the LED is on steady, turn the ignition key "on" and "off".

**NOTE:** if, during this phase the ignition key is switched on for more than 5", the system will consider it this as a theft attempt, causing another alarm condition.

- The installed LED will turn off, showing the beginning of the unlock procedure.
- 4" after the LED goes out, it will start flashing 9 times.
- As soon as the number of blinks is equal to the first digit of the PIN-CODE, connect and disconnect the ignition key switch, so confirming the first digit of the code.
- After another , the LED will start flashing again 9 times.
- As soon as the number of blinks is equal to the second digit of the PIN-CODE, connect and disconnect the ignition key switch, so confirming the second digit of the code.
- Repeat this procedure for the remaining two digits of the PIN-CODE.
- When the last digit is entered, the system will be deactivated and signalled as indicated in the paragraph "system disarming with alarm memory".

## 6.0 - EXAMPLE OF SYSTEM UNLOCK BY PIN-CODE

To better understand the alarm system unlock by means of PIN-CODE, please refer to the following example considering a PIN-CODE with digits 2-3-4-1.

Arm the system, wait until the end of the "neutral time" and then trigger an alarm condition.

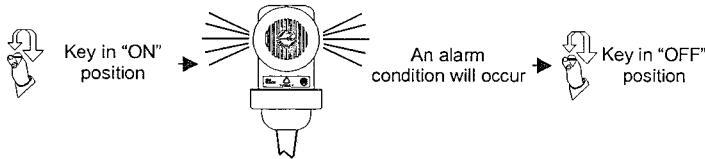

When the alarm signals are over, the LED on the vehicle will turn ON steady for about 5".

While the LED is on, turn ignition key "on" and "off". The LED will go out to indicate the beginning of the disarming procedure by PIN-CODE.



4" after the LED goes out, it will start flashing. Count the flashes.

When the number of flashes equals the first digit of the PIN-CODE (in this case 2), turn ignition key "on" and "off".

After another 4", the LED will start flashing again.

When the number of flashes equals the second digit of the PIN-CODE (in this case 3), turn ignition key "on" and "off" again.

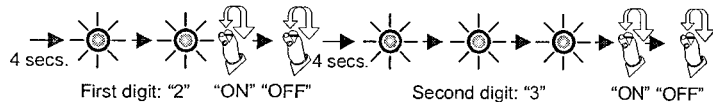

After another 4", when the flashing starts again, count the number of flashes to set the other two digits (in this case 4 and 1).

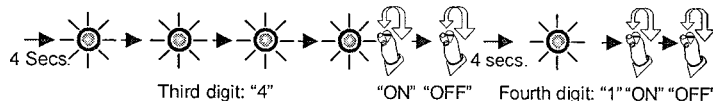

When the fourth digit is set, the alarm system disarms and indicates the last cause that triggered the alarm.

## 7.0 - PIN-CODE PERSONALIZATION

The PIN-CODE procedure allows disarming the alarm system in case of emergency when, for any reason, the remote control or the electronic key cannot be used.

To obtain system disarming, you must enter a 4-digit numeric code, by default 1-1-1-1.

For security reasons, we recommend to replace this default code with your own personal code.

To modify the default code it is best to contact PIAGGIO technical assistance, otherwise proceed as follows.

- If the system is not disarmed, make sure you disarm it.
- Turn ignition key "ON"; the LED will light up for about one second.
- During this lapse of time, press simultaneously both buttons on the remote control; the LED on the vehicle will light up steady and 2 acoustic signals will sound, one low-tone (BOOP) and one high-tone (BEEP), to confirm activation of the procedure.
- Open the seat or the top case (system 602687M) or connect to positive the BLACK-BLUE wire (systems 602688M and 602689M). The LED on the vehicle must light up steady.
- Press both buttons on the remote control.
- Turn ignition key "OFF". The LED will go out to confirm the system is in the PIN-CODE procedure.
- After 4 seconds, the LED on the vehicle will start flashing 9 times. Count the flashes. When the number of flashes equals the first digit to enter, turn ignition key "ON" and "OFF".
- After another 4", the LED flashes another 9 times; when the number of flashes equals the second number to enter, turn ignition key "ON" and then "OFF".
- Repeat the above operation for the remaining two digits of the PIN-CODE.
- Once the last digit is set, the system will automatically exit from the procedure and confirm it with two low-pitched acoustic signals (BOOP) and one high-pitched signal (BEEP). Disconnect the BLACK-BLUE wire from positive or close the seat/top case if the vehicle is equipped with a safety push-button.

## 8.0 - PROGRAMMING OF THE SYSTEM

The alarm system can be configured according to one's needs by activating or deactivating the following functions:

- Acoustic signals when arming/disarming (CHIRP).
- Panic alarm.
- Shock sensor.

The alarm system comes with all these functions activated.

To modify any of them proceed as follows.

- If the system is not disarmed, make sure you disarm it.
- Turn the ignition key "ON"; the LED will turn on for a second.
- During this lapse of time, press simultaneously both buttons on the remote control; the LED on the vehicle will light up steady and 2 acoustic signals will sound, one low-tone (BOOP) and one high-tone (BEEP), to confirm activation of the procedure. The first of the three programmable functions (CHIRP) can now be activated or deactivated.
- To activate this function, press the button n.1 (dotted) on the remote control. A high-pitched acoustic signal (BEEP) will confirm activation.
- To exclude this function, press the button n.2 (smooth) on the remote control. A low-pitched acoustic signal (BOOP) will confirm deactivation.
- When the first function has been programmed, the system automatically goes to the second function (panic alarm). To activate or deactivate this function proceed as described above. The system will then automatically go to the third and last programmable function.
- When all the functions have been programmed as required, the system will automatically exit the procedure. The LED on the vehicle will go out and two acoustic low-tone signals (BOOP) and one high-tone (BEEP) will confirm the end of this procedure.

## 9.0 - LEARNING OF NEW DEVICES

Depending on the systems, they are supplied with a remote control (602689M) or with a remote control and an electronic key (602687M and 602688M).

To add other devices, if required, proceed as follows:

- Disarm the alarm system.
- Turn the ignition key "ON"; the LED will turn on for a second.
- Within this lapse of time, insert an already programmed electronic key in its receptacle or use an already programmed remote and press FIRST the dotted button and IMMEDIATELY AFTER the smooth button.
- A long acoustic low-pitched signal, a long acoustic high-pitched signal and two flashes of the turn indicators will confirm the learning procedure.
- Press any button on the remote control to self-learn or insert the key to self-learn in the receptacle.
- A short high-pitched acoustic signal and a short flash of the LED installed on the vehicle will confirm the learning of the new device.
- When the devices have been programmed, turn ignition key "OFF"; a low-pitched acoustic signal and a flash of the turn indicators will confirm the end of the procedure.

**OR:**

- Make sure the alarm system is disarmed and then connect to ground the WHITE-PURPLE wire from the alarm harness.
- Turn the ignition key "ON"; a long acoustic low-pitched signal, a long acoustic high-pitched signal and two flashes of the turn indicators will confirm the learning procedure.
- Press any button on the remote control to self-learn or insert the key to self-learn in the receptacle.
- A short high-pitched acoustic signal and a short flash of the LED installed on the vehicle will confirm the learning of the new device.
- When the devices have been programmed, turn ignition key "OFF" and remove the WHITE-PURPLE wire from ground; a low-pitched acoustic signal and a flash of the turn indicators will confirm the end of the procedure.

## **10.0 - UTILITY FUNCTION**

These alarm systems have a built-in utility function which can further reduce the already very low current absorption to extend even more the vehicle battery life.

The function can be activated in three different ways:

- Manual activation, completely managed by the user (systems 602687M and 602688M).
- Automatic activation when the system has not been used for 2 months.
- Automatic activation, 72 hours after system activation.

### **10.1 - MANUAL UTILITY FUNCTION WITH SYSTEM DESACTIVATED** **(602687M, 602688M)**

If the vehicle is stored for a long period of time (i.e. For the winter season), the user can place the alarm system in stand-by.

This procedure simulates the disconnection of the device from the vehicle electrical system, eliminating therefore any power absorption.

To activate the feature proceed as follow:

- If the system is not disarmed, make sure you disarm it.
- Turn ignition key "ON"; the LED installed on the vehicle will flash for a second.
- Wait until the LED goes out and within the next 5" insert the electronic key in its receptacle.
- The alarm system will immediately go in "stand-by" mode confirmed by a high-pitched acoustic signal.
- Turn ignition key "OFF".
- In stand-by mode the alarm system stops working; to reactivate normal operation just turn ignition key "ON" and "OFF".

### **10.2 - AUTOMATIC UTILITY FUNCTION WITH SYSTEM DISARMED** **(all systems)**

If the vehicle and the alarm system are stored for a long period of time, at least 2 months, they will automatically go in stand-by.

The system goes in stand-by mode without user intervention.

Also in this case, to exit the stand-by mode, simply turn ignition key "ON" and "OFF".

## **10.3 - AUTOMATIC UTILITY FUNCTION WITH SYSTEM ARMED** **(all systems)**

With this feature the alarm system excludes from operation only a part of its accessories.

This reduces power consumption even more while keeping the vehicle protected.

If no alarm is triggered, 72 hours after the system is activated, the radio receiver is automatically excluded.

In this condition, depending on the type of device, to disarm the alarm system proceed as follows.

#### **602689M:**

- Turn ignition key "ON" and keep it on for a second.

***NOTE: if ignition key is switched on for more than 3", the system will consider it a theft attempt and trigger immediately an alarm.***

- Turn the vehicle ignition key in "OFF".
- Push the button n. 1 (dotted) on the remote.
- The system will disarm and the operation confirmed by the audio/visual signals as described in the chapters "system disarming without alarm memory" or "system disarming with alarm memory".

#### **602687M, 602688M:**

- Insert the electronic key into its receptacle.
- The system will disarm and the operation confirmed by the audio/visual signals as described in the chapters "system disarming without alarm memory" or "system disarming with alarm memory".

## INSTALLER MANUAL

### 11.0 - PRELIMINARY ADVICE

Thank you for purchasing an original PIAGGIO accessory.

- Please read this manual carefully and in its entirety as it will guide you through the proper installation.
- To carry out the installation properly, make sure you follow every required step precisely.
- All information provided in this manual is based on the technical features of the PIAGGIO alarm systems.
- PIAGGIO original accessories have been designed for this alarm system and they have been tested on it. As the manufacturer cannot check their market availability, the installer or the final user of the vehicle shall bear the risk of selecting the part.
- Information and features contained in this manual are up-to-date at the time of issue. PIAGGIO reserves the right to make changes at any time without prior notice.
- This manual provides instructions for the three PIAGGIO alarm systems. Make sure you follow the ones for the system you are installing. The type of alarm will be specified at the beginning of each chapter.

### 12.0 - TECHNICAL DATA

Power supply	12 Vdc
Power supply range	9Vdc-15Vdc
Current absorption @ 12-Vdc	<1mA (system armed and LED flashing)
Sound power radiated	118 dBA at a meter
Working range temperature	-20°C/+85°C

### 13.0 - INSTALLATION OF THE UNIT (602687M, 602688M, 602689M)

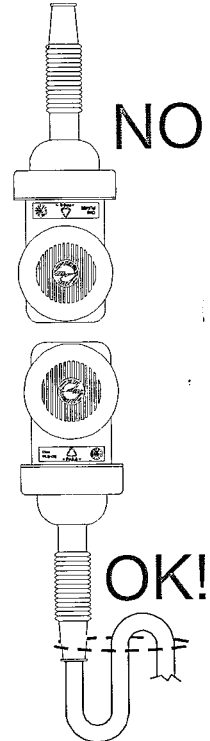

Do not install the alarm system in this position because water may infiltrate through the rubber cap and permanently damage the electronic circuit making the alarm system unreliable.

The warranty does not cover malfunctioning due to water infiltration.

- Installing the control unit in this position, will prevent water entering the unit through the rubber cap.
- It is important to give the wire sheath a syphon-like bending and secure it with a tie wrap.
- The control unit must not be exposed to atmospheric agents but must be installed in such a way as not to muffle the siren.
- The control unit must be installed away from moving mechanical parts, electric or electronic components that could generate high frequency electromagnetic disturbances and away from devices that could reach high temperatures when the vehicle is in use.
- The control unit must not be installed directly on the vehicle frame.

If you use a jet wash to clean your vehicle, protect it from water splashes and be careful not to expose the alarm to the high pressure jet. This warranty will not cover damages to the system due to water infiltrations caused by improper installation, improper jet washing or the use of non original accessories, not approved by the manufacturer

## 14.0 - POSITIONING OF THE ACCESSORIES (602687M, 602688M, 602689M)

Accessories are a fundamental part to obtain a very efficient alarm system. The flashing red LED, for example, indicates that the vehicle is protected by an alarm system.

Hereafter is a list of all the accessories required by the alarm system and their correct positioning.

### Note for installation of the receptacle for electronic key end LED holder:

- Before drilling a hole in the plastic part of the vehicle, check the position of the handlebars with the steering lock engaged. Make sure the receptacle (or the LED) is not covered by the handlebars when the vehicle is parked.
- Be careful when drilling so as not to damage a part of the vehicle.
- Make sure you drill a hole of the right diameter so as not to damage the plastic parts and avoid having to replace them.
- The diameter of the hole to be drilled for the LED holder is 10mm; the one for the receptacle 13mm.

### 14.1 - RECEPTACLE FOR ELECTRONIC KEY WITH BUILT-IN LED (602687M, 602688M)

The receptacle with built-in LED must be installed where it can readily be seen and accessed by the user.

The electronic key is the device used to disarm the alarm system in case emergency (i.e. When the remote control is lost).

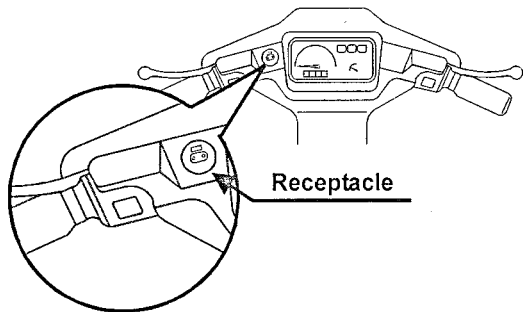

### 14.2 - LED HOLDER (602689M)

The LED holder must be installed where it can be clearly seen from afar.

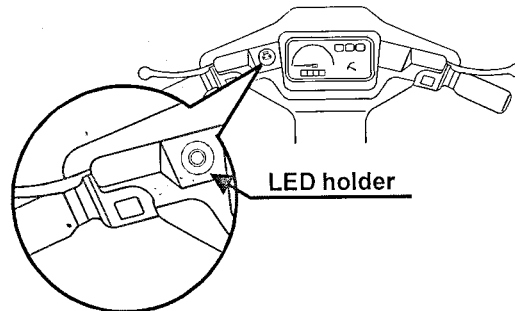

### 14.3 - PERIMETRIC PUSH-BUTTON (602689M, 602688M)

Some vehicles are not accessorized with a push-button to protect the seat and top case.

If required, one can be installed as follows:

- It must be installed in such a way as to detect the opening of the seat/topcase without being accessible from the outside.
- The trigger threshold must be carefully set to avoid false alarms.
- The BLACK-BLUE wire of the alarm wiring must be connected to the push-button terminal.
- The push-button terminal, which must be connected to positive, must be connected to a permanent positive wire (battery). Make sure you don't use push-buttons with a fixing eyelet connected directly to their terminal.

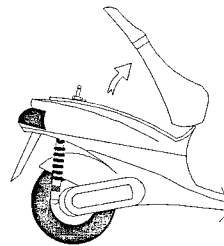

**Note on the installation of the seat/top case push-button:**  
Installation of this push-button is not mandatory.

If the BLACK-BLUE wire is not used it should be positioned in a hidden but easily accessible spot.



## 15.0 - ELECTRICAL CONNECTIONS (602687M, 602688M, 602689M)

Once the alarm unit and the accessories are installed, make the electrical connections between the alarm system wiring harness and the vehicle electrical equipment.

These will vary according to the alarm system you are installing.

### 15.1 - ELECTRICAL CONNECTIONS IN PRE-EQUIPPED VEHICLES (602687M)

- Locate the cable-ready connector for plugging the alarm system.
- Plug the alarm wiring interface into this connector.

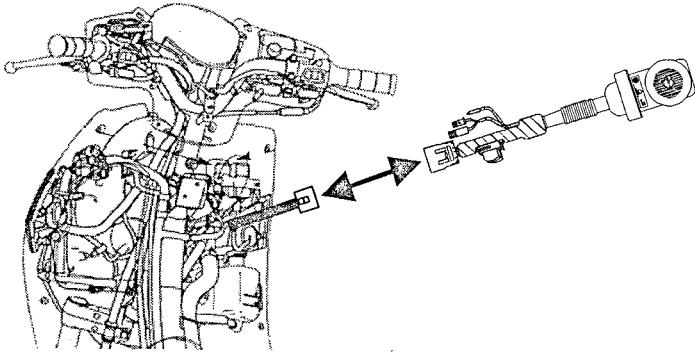

### 15.2 - ELECTRICAL CONNECTIONS IN NOT PRE-EQUIPPED VEHICLES (602688M and 602689M)

- Find on the vehicle the connectors of the ignition key.
- Disconnect the ignition connector from the vehicle electrical equipment connector.
- Plug the two alarm wiring connectors, one into the ignition key connector and the other into the vehicle electrical system connector.

**NOTE:** connectors cannot be inverted because they are polarized.

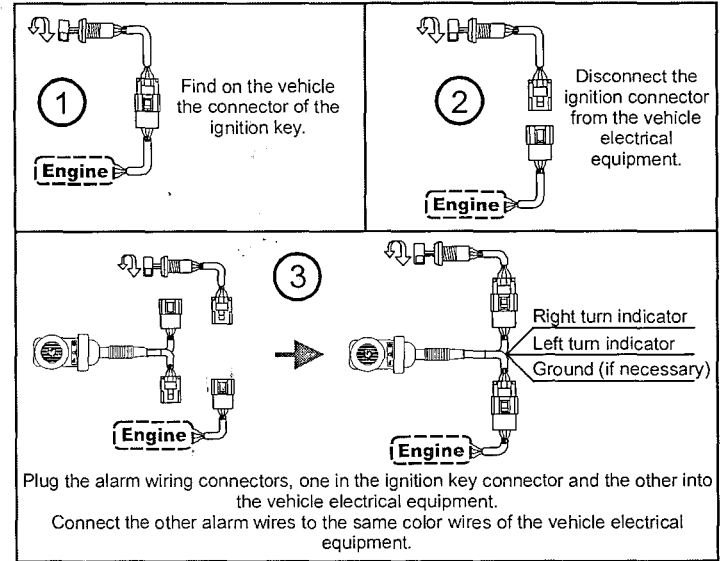

Complete the electrical connections of the alarm system.

- Connect the wires which give a positive feed to the turn indicator lamps to the same color wires of the alarm system wiring harness (vehicle PINK wire to alarm wiring PINK wire, vehicle WHITE-BLUE wire to alarm wiring WHITE-BLUE wire).
- Where necessary (usually only on vehicles with a cylinder capacity exceeding 50cc and engine immobilized by circuit interruption), connect the BLACK wire of the alarm wiring to one of the BLACK wires which give a negative feed to the turn indicators lamps.
- Plug the connector of the receptacle for electronic key (only for 602687M and for 602688M) to the corresponding connectors of the alarm wiring.
- Connect the LED holder connector (only for 602689M) to the corresponding connector of the alarm system wiring harness.

**NOTE:** NEVER connect the BLACK wire of the alarm wiring to the vehicle frame, it does not ensure a good ground connection.

## 16.0 - SHOCK SENSOR ADJUSTMENT (602687M, 602688M, 602689M)

Complete the installation by adjusting the shock sensor sensitivity level and closing the unit as described in the following paragraphs.

- Locate, inside the alarm unit, the shock sensor sensitivity adjustment trimmer (see figure below).

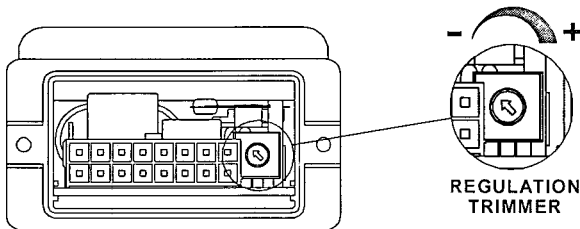

- Adjust the trimmer at about half of its scale.
- Arm the alarm system and wait until the neutral time is over (the LED will start flashing).
- Firmly strike the vehicle without damaging any plastic part of the frame.
- If the system does not detect the shock, disarm it, turn the sensor clockwise to increase the sensitivity level and retest.
- If the alarm system triggers too easily, disarm the alarm system, turn the sensor counterclockwise to decrease the unit sensitivity and retest.

**NOTE:** calibrate the sensor carefully with the right sensitivity level so that it works reliably as a protective measure without triggering useless false alarms.

## 17.0 - CLOSING OF THE CONTROL UNIT (602687M, 602688M, 602689M)

Position the wiring rubber cap over the external edge of the alarm housing.

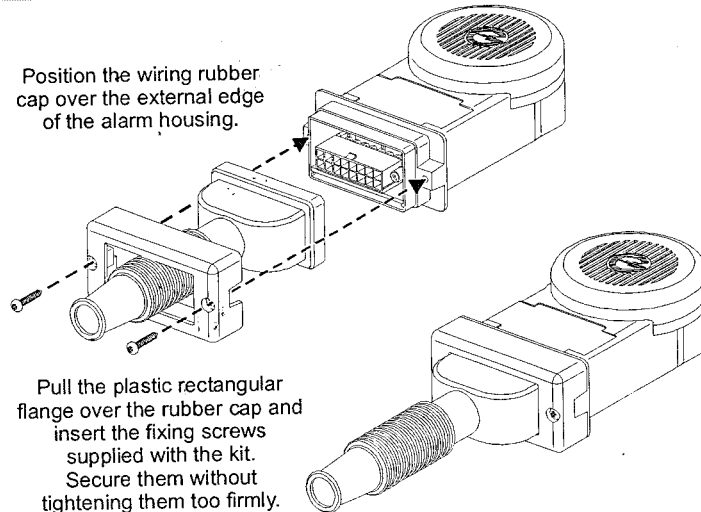

Pull the plastic rectangular flange over the rubber cap and insert the fixing screws supplied with the kit. Secure them without tightening them too firmly.

## 18.0 - WASTE ELECTRICAL AND ELECTRONIC EQUIPMENT (WEEE) DIRECTIVE

The present device does not fall within the scope of Directive 2002/96/EC on Waste Electrical and Electronic Equipment (WEEE) as specified in art. 2.1 of L.D. no. 151 of 25/07/2005.